

PEDAL POWER MONDO

User's Manual

www.voodoolab.com

Copyright ©2012 by Digital Music Corporation.

This publication is protected by copyright and all rights are reserved. Voodoo Lab and Pedal Power are trademarks of Digital Music Corp.

rev 1.0

TABLE OF CONTENTS

Introduction	2
Unpacking	3
Connections	3
DIP Switches	5
DC Power Cables	6
Strymon	6
Boss	6
Line 6	7
TC Electronic	7
Eventide	7
Additional Cables	8
About Isolation	9
Specifications	10
Warranty	11
How to Reach Us	11

Introduction

Pedal Power MONDO is a high-current capable supply that can power the largest and most diverse pedalboards. With twelve independent, filtered and regulated output sections, Pedal Power MONDO can properly power modern DSP-based effects and all 9V battery operated pedals and accessories.

Nearly all DSP-based effects made today are supplied with digital switching power adapters, which produce significant high frequency noise. Because Pedal Power MONDO is an audiophile quality linear (analog) supply, there are no digital artifacts to introduce into your signal path. And, its ultra low-noise design keeps the most sensitive vintage and boutique analog pedals dead quiet.

All linear, transformer-based power supplies generate heat. While other high-power linear supplies operate at excessively high internal temperatures (which will limit their long term reliability), Pedal Power MONDO includes many exclusive design features to keep internal temperatures within proper limits to guarantee long-term reliability.

Designed to meet the needs of professional users, Pedal Power MONDO provides clean, consistent power, even under the poor AC line conditions often found on stage. Completely isolated output sections eliminate ground loops and unwanted interactions between effects, resulting in lower noise and noticeably improved tone.

All Voodoo Lab products are designed and manufactured in the U.S.A.

Unpacking

Your Voodoo Lab Pedal Power MONDO box should contain the following:

Pedal Power MONDO unit

Warranty card

AC line cord

DC Power cables:

- 5.5x2.1mm right angle barrel connectors (10)

- 5.5x2.1mm straight barrel connectors (2)

- 5.5x2.5mm right angle “red” barrel (5)

- 3.5mm right angle mini plug (1)

- 9V battery snap (1)

Connections

Pedal Power MONDO is powered directly from mains using the supplied AC line cord. This is a standard computer-type IEC line cord, so it’s easy to obtain a replacement or different length.

Important: Pedal Power MONDO is manufactured to operate from a specific supply voltage (100V, 120V or 240V) which is marked on the bottom of the unit. Attempting to operate at the wrong voltage may cause permanent damage.



(1) AC auxiliary. This is a courtesy AC outlet for convenient powering of AC powered effects or a MIDI foot controller. Note the 200 watt maximum rating. Do NOT plug in your amp here!

(2) AC power input jack. This is a standard “IEC-type” connector.

All 9V outputs can also power ordinary low-current battery operated pedals.

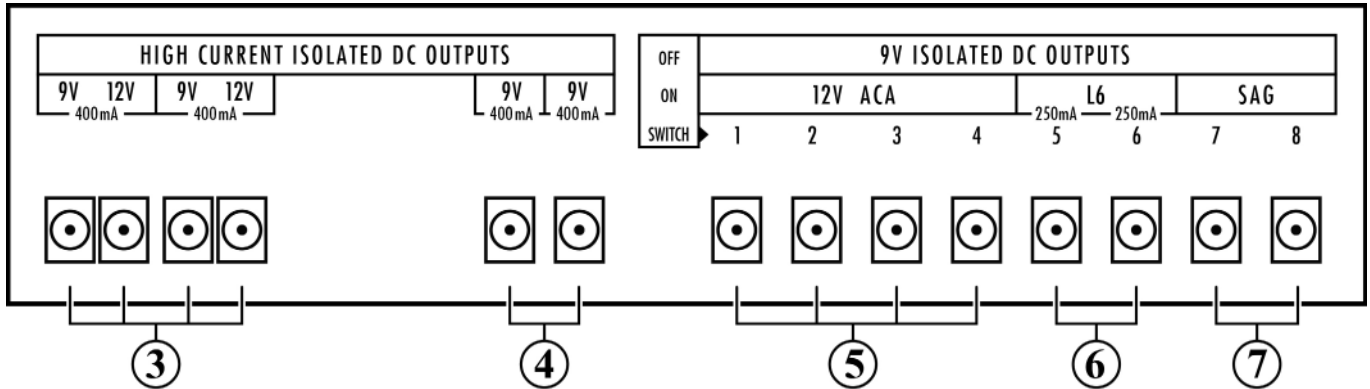

(3) 9V and 12V high-current output pairs. Each pair is an isolated output section providing up to 400mA.

Note: The 9V and 12V outputs within a pair are not isolated from each other. It is preferred to use only one from each pair. If using both, combined output should not exceed 400mA.

(4) 9V high-current outputs. Use for all devices which require 400mA or less.

(5) 9V (or 12V) outputs. Use for all pedals which operate from a 9V battery or require less than 100mA. Switchable to 12V via DIP switches.

(6) 9V (or L6) outputs. Use with 9V battery or high-current effects that require less than 250mA. Switchable to L6 mode (unregulated 12V) via DIP switches.

(7) 9V (or SAG) outputs. Use for all pedals which operate from a 9V battery or require less than 100mA. Allows you to SAG voltage from 9V down to about 4V. Enable SAG control via DIP switches.

DIP Switches

On the bottom of MONDO is an 8 position DIP switch numbered 1-8. These switches correspond to outputs labeled 1-8 and select the output voltage. The switches should be in the OFF position for standard 9V operation. Setting a switch to ON enables the alternate voltage.

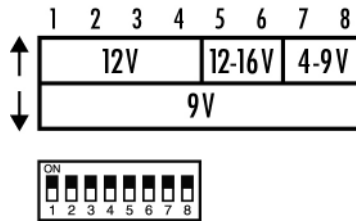

Switches 1-4. These select 12V at 60mA. This is commonly used for battery operated Boss pedals which specify the ACA type power supply.

Switches 5-6. These select unregulated 12V at 250mA. Since it is unregulated, actual voltage will vary from 12V at 250mA up to about 16V when lightly loaded. The most common use is for Line 6 modeling pedals such as DL4 and MM4.

Switches 7-8. These enable SAG controls. When switched on, the voltage is determined by the SAG control. You can adjust the voltage from 9V down to 4V to simulate a dying battery.

DC Power Cables

The Pedal Power end of each supplied DC power cable has a black barrel connector. The other end has either another identical barrel connector (center negative), a 5.5x2.5mm *red* barrel (center positive) or a 3.5mm mini-plug (tip positive). Use the standard black barrel connector cables with most common 9V battery operated pedals.

Before powering your pedal with a standard black barrel connector, you must verify that the pedal requires “center negative” polarity to prevent damage. Some common exceptions with their power jacks wired for “center positive” are the Fulltone ‘69, SoulBender, and Octafuzz pedals and Moogerfoogers. Reverse polarity cables are available from Voodoo Lab to properly power these pedals.

Strymon

All Strymon pedals (including the larger format Timeline) can be powered from any of the high-current 400mA 9V outputs using a standard black 5.5x2.1mm barrel cable.

Important: *Strymon pedals should **only** be powered from the 9V outputs. Attempting to power from a 12V output will permanently damage the pedal. Don't do it, we warned you!*

Boss Pedals

There are two types of Boss pedals which operate from a 9V battery. These are identified by the type of power supply specified, either PSA or ACA. Almost all Boss pedals specify the PSA type adapter and operate at 9V. Boss pedals which specify the ACA type adapter require a higher voltage and should be powered by a 12V ACA output (via DIP switches). Boss Twin pedals, such as the DD-20, require more than 100mA and can be powered from any 9V high-current (250mA or 400mA) output.

Line 6

Tone Core pedals, plus Pocket POD can be powered from any available 9V output. The M5 must use a 400mA high-current output with a standard *black* 5.5x2.1mm barrel cable.

You can power Line 6 modeling pedals, DL4 or MM4, using the *red* 5.5x2.5mm barrel cable from either the 12V 400mA high-current outputs or outputs 5 and 6 with the DIP switch in the ON position. This does not match the rating of the supplied Line 6 adapter, but does correctly power these pedals. Note that PODxt & HD, M9, M13 and the JM4 Looper cannot be powered by Pedal Power MONDO.

TC Electronic

TC Electronic's Nova pedals such as the Delay, Modulator and Reverb are powered from any high-current 400mA 12V output, or L6 250mA 9V output using a standard black 5.5x2.1mm barrel cable. This does not match the rating of the supplied TC Electronic adapter, but does correctly power these pedals.

Other TC Electronic pedals which can be powered from a 9V battery, such as the Classic and TonePrint series, can operate from any 9V output.

Eventide

The Eventide stompboxes (TimeFactor, ModFactor, PitchFactor and Space) can be powered from any 9V or 12V high-current 400mA output using the *red* 5.5x2.5mm barrel cable. The 12V output does not match the rating of the supplied Eventide adapter, but does correctly power these pedals.

Important: While you can power the Eventide stompboxes from either 9V or 12V high-current outputs, do NOT operate two Eventide pedals from the same isolated section by using both 9V and 12V jacks of the pair. This WILL exceed the 400mA current rating.

Additional Cables

The DC power cables supplied with your Pedal Power MONDO are suitable for most common pedal effects. If you need additional cables, different lengths, reversed polarity, or a special connector, these are available from Voodoo Lab at our online store.

Also available are adapter cables:

Split Output Adapter. Provides two output jacks from a single Pedal Power MONDO output. One side is ground lifted to minimize the possibility of ground loops and added noise.

Voltage Doubler Adapter. Combines two Pedal Power MONDO outputs to make 18V or 24V. Ideal for MXR Flanger and various Fulltone and Keeley products.

See the entire selection and purchase cables online at:

www.voodoolab.com/cables.htm

About Isolation

Pedal Power MONDO has 12 isolated output sections. This is sometimes referred to as “galvanic isolation” and means that there is no direct electrical connection between each output. Similarly, when you power your effects with batteries, they are also isolated because there is no electrical connection between the batteries.

Most power supplies are not isolated. Their output jacks are simply bussed together or use a daisy chain cable. This allows unwanted electrical current to flow between the outputs, commonly called a ground loop. The result is added noise. The isolated outputs of Pedal Power MONDO eliminate this noise.

Another benefit of isolation is that you can power both negative ground and positive ground effects with Pedal Power MONDO. Negative ground effects are by far the most common, however the Fuzz Face and Octavia are some well known examples of positive ground circuits. Attempting to power positive ground pedals together with negative ground pedals from a non-isolated power supply will not work and may even damage the supply.

There are a couple of other tricks you can get from an isolated supply like Pedal Power MONDO. You can use a special Y-cable (voltage doubler cable) which connects two 9V outputs in series to provide an isolated 18V, or use the 12V outputs to get 24V. Occasionally, a pedal requires a bipolar supply, using two batteries for +9V and -9V. Isolated outputs work fine for this, non-isolated supplies do not.

Voodoo Lab has been the pioneer of isolated power supplies for guitar pedal effects since 1996.

Specifications

Input: Standard IEC connector
120V 60Hz (North America model)
100V 50/60Hz (Japan model)
220-240V 50Hz (Europe/Australia model)

Model and input power are marked on bottom of unit.

Outputs: 5.5x2.1mm barrel connectors center negative
Linear regulation
Short circuit protected

Two 9VDC + 12VDC (400mA)

Two 9VDC (400mA)

Two 9VDC (250mA)

Four selectable 9VDC (100mA) or 12VDC (60mA)

Two 9VDC (100mA) with SAG controls

Physical: 10.7" wide x 3.4" deep x 1.8" tall (272 x 86 x 45 mm)
2.8 lbs (1.3 kg)

Special: Two toroidal power transformers
Variable speed silent cooling fan

Warranty (North America only)

Voodoo Lab warrants this product against defects that are due to faulty material or workmanship for a period of five years from the date of original retail purchase. This warranty does not include damage to the product resulting from accident or misuse. This warranty is given to the original purchaser only and it is not assignable to any other person.

If the product should become defective within the warranty period, Voodoo Lab will repair it or replace it free of charge, provided it is returned freight prepaid to Voodoo Lab with a valid RMA (return material authorization) number.

This warranty shall not apply to any goods that have been repaired or altered by anyone other than the manufacturer. There are no warranties which extend beyond the terms described herein. Should you experience any difficulty with this Voodoo Lab product, contact us as described below. If it is determined that the product must be returned to the factory for repair, you will be issued an RMA and given shipping and packaging instructions.

Warranty (outside North America)

Outside North America, please contact your region's distributor for warranty information.

How to Reach Us

You can reach us by any of the following:

Tel: 707 545 0600

Mail: Voodoo Lab

3165 Coffey Lane, Santa Rosa, CA 95403 U.S.A.

Email: info@voodoolab.com

Please check our forum for answers to common questions:

www.voodoolab.com/forum